

ELECTRONIC VALVE SPECIFICATIONS

SPECIFICATION CV7277-7310

ISSUE No.1 DATED 1.5.1963

AMENDMENT NO.1

Pages 4 and 5.

Delete these pages, and insert the attached  
new pages 4 and 5.

Admiralty Surface Weapons Establishment

July, 1963  
(190346)

## MILITARY SPECIFICATION

## CV7277 - 7310

SEMICONDUCTOR DEVICES,  
VOLTAGE REGULATOR DIODES

Description:- This specification covers the detail requirements for Silicon Double Anode (Clipper) Voltage - regulator Diodes and is in accordance with K1007 except as otherwise specified.

Mechanical Dimensions and Outlines:- K1007, Section B, 10.3.3.2 (10-32 UNF 2A thread).

Absolute Maximum Ratings:-

Rating	P <sub>tot</sub>	T <sub>stud</sub>	T <sub>opr</sub>	T <sub>stg</sub>	Shock	Vibration	
Unit	W	°C	°C	°C	g	g	
Min.	-	-	-55	-55	-	-	
Max.	10	150	150	150	1500	20	
Note	1				2		

NOTES:- 1. See derating curve Fig. 1 page 13.

2. Duration 0.5 ms.

# CV7277-7310

## Primary Electrical Characteristics

1	2	3	4	5	6	7	
	V <sub>(BR)</sub> nominal	V <sub>(BR)</sub> min.	V <sub>(BR)</sub> max.	I test	Z <sub>(BR)</sub> max.	Z <sub>(BR)</sub> max.	
	V	V	V	mA	Ω	Ω	
CV7277	6.2	5.8	6.6	500	4	700	
CV7278	6.8	6.4	7.2	200	4	450	
CV7279	7.5	7.1	7.9	200	2.5	450	
CV7280	8.2	7.7	8.7	200	2.5	450	
CV7281	9.1	8.6	9.6	200	2.5	450	
CV7282	10.0	9.4	10.6	200	2.5	450	
CV7283	11.0	10.4	11.6	200	2.5	450	
CV7284	12.0	11.4	12.6	200	2.5	450	
CV7285	13.0	12.4	14.1	200	2.5	450	
CV7286	15.0	13.9	15.6	100	5	450	
CV7287	16.0	15.4	17.1	100	5	450	
CV7288	18.0	16.9	19.1	100	5	450	
CV7289	20.0	18.9	21.2	100	5	450	
CV7290	22.0	20.8	23.3	100	5	450	
CV7291	24.0	22.7	25.9	100	5	450	
CV7292	27.0	25.1	28.9	100	5	450	
CV7293	30.0	28.0	32.0	100	8	500	
CV7294	33.0	31.0	35.0	50	8	500	
CV7295	36.0	34.0	38.0	50	8	500	
CV7296	39.0	37.0	41.0	50	8	500	
CV7297	43.0	40.0	45.0	50	10	600	
CV7298	47.0	44.0	50.0	50	10	600	
CV7299	51.0	48.0	54.0	50	10	700	
CV7300	56.0	53.0	60.0	50	10	700	
CV7301	62.0	58.0	66.0	50	15	800	
CV7302	68.0	64.0	72.0	20	50	800	
CV7303	75.0	71.0	79.0	20	50	800	
CV7304	82.0	77.0	87.0	20	50	900	
CV7305	91.0	86.0	96.0	20	60	1000	
CV7306	100.0	94.0	106.0	20	60	1100	
CV7307	110.0	104.0	116.0	20	60	1300	
CV7308	120.0	114.0	126.0	20	80	1400	
CV7309	130.0	124.0	141.0	20	80	1500	
CV7310	150.0	139.0	156.0	10	180	1700	
Conditions	I	See Col. 5			See Col. 5		1.0
	T <sub>stud</sub>	100			25		25

Primary Electrical Characteristics (Cont'd.)

	1	2	3	4	5
		$S_z$ min.	$S_z$ typical	$S_z$ max.	$Z(BR)$ max.
		%/°C	%/°C	%/°C	$\Omega$
CV7277		-0.01	0.03	0.07	1050
CV7278		-0.01	0.03	0.07	675
CV7279		0	0.04	0.08	675
CV7280		0	0.04	0.08	675
CV7281		0.01	0.05	0.09	675
CV7282		0.01	0.05	0.09	675
CV7283		0.01	0.05	0.09	675
CV7284		0.015	0.055	0.095	675
CV7285		0.015	0.055	0.095	675
CV7286		0.02	0.06	0.10	675
CV7287		0.02	0.06	0.10	675
CV7288		0.02	0.06	0.10	675
CV7289		0.02	0.06	0.10	675
CV7290		0.02	0.06	0.10	675
CV7291		0.02	0.06	0.10	675
CV7292		0.02	0.06	0.10	675
CV7293		0.02	0.06	0.10	750
CV7294		0.02	0.06	0.10	750
CV7295		0.03	0.07	0.11	750
CV7296		0.03	0.07	0.11	750
CV7297		0.03	0.07	0.11	900
CV7298		0.03	0.07	0.11	900
CV7299		0.04	0.08	0.12	1050
CV7300		0.04	0.08	0.12	1050
CV7301		0.04	0.08	0.12	1200
CV7302		0.04	0.08	0.12	1200
CV7303		0.05	0.09	0.13	1200
CV7304		0.05	0.09	0.13	1350
CV7305		0.06	0.10	0.14	1500
CV7306		0.06	0.10	0.14	1650
CV7307		0.06	0.10	0.14	1950
CV7308		0.06	0.10	0.14	2100
CV7309		0.06	0.10	0.14	2250
CV7310		0.06	0.10	0.14	2550
Conditions	I      mA	See Col. 5 Page 2			1.0
	T <sub>stud</sub> °C	25-100			25

# CV7277-7310

## Applicable Documents:-

T.V.C. Information Sheets Nos. 9 and 10

## Requirements:-

Marking. K1007, Section B, 1.3.4. Minimum requirements 1.3.4.1 (a) and (b)

## Quality Assurance Provisions:-

Destructive Tests. The tests listed in Table II Group B Inspection, Subgroup 2 and 3, and in Table III Group C Inspection, Subgroup 2 are considered destructive.

Group C Inspection. Inspection shall be conducted on the initial lot and thereafter every 90 days or every fifth lot whichever occurs first.

## Preparation for Delivery:-

Packaging. The devices shall be packed according to K1007, Section A 1.2 (c). Items 1 to 6 inclusive shown in Fig. 2 page 14 shall be packed with each device.

## Joint Service Catalogue Numbers:-

CV7277	5960-99-037-2684	CV7292	5960-99-037-2699
CV7278	5960-99-037-2685	CV7293	5960-99-037-2700
CV7279	5960-99-037-2686	CV7294	5960-99-037-2701
CV7280	5960-99-037-2687	CV7295	5960-99-037-2702
CV7281	5960-99-037-2688	CV7296	5960-99-037-2703
CV7282	5960-99-037-2689	CV7297	5960-99-037-2704
CV7283	5960-99-037-2690	CV7298	5960-99-037-2705
CV7284	5960-99-037-2691	CV7299	5960-99-037-2706
CV7285	5960-99-037-2692	CV7300	5960-99-037-2707
CV7286	5960-99-037-2693	CV7301	5960-99-037-2708
CV7287	5960-99-037-2694	CV7302	5960-99-037-2709
CV7288	5960-99-037-2695	CV7303	5960-99-037-2710
CV7289	5960-99-037-2696	CV7304	5960-99-037-2711
CV7290	5960-99-037-2697	CV7305	5960-99-037-2712
CV7291	5960-99-037-2698	CV7306	5960-99-037-2713

Joint Service Catalogue Numbers (cont'd.)

CV7307	5960-99-037-2714
CV7308	5960-99-037-2715
CV7309	5960-99-037-2716
CV7310	5960-99-037-2717

This specification has been prepared by and the Qualification Approval Authority is:-

Admiralty Surface Weapons Establishment,  
Portsmouth, Gosport, Hants, England.

GROUP A INSPECTION

Table I  
Page 6

Examination or Test	Test Conditions		AQL %	Insp. Level	Sym- bol	Limits		Units
	K1007/ NATO Ref.	Specific Conditions				Min.	Max.	
<u>SUBGROUP 1</u> Visual and Mechanical Inspection	5.1	Excluding Physical Dimensions	0.65	II				
<u>SUBGROUP 2</u> Breakdown Voltage (1)	8A.2.4	Stud Positive Tstud = 100°C + 2°C. I = see Col. 5, page 2. Single shot pulse, 0.1 sec duration, max. tr and tf = 10 mS.	0.65	II	$\sqrt{BR}$	Col. 3 page 2	Col. 4 page 2	V
Breakdown Voltage (2)	8A.2.4	Stud Negative Tstud = 100°C + 2°C. I = see Col. 5, page 2. Single shot pulse, 0.1 sec duration, max. tr and tf = 10 mS.			$\sqrt{BR}$	Col. 3 page 2	Col. 4 page 2	V
Small Signal Breakdown Impedance (1)	8A.4.1	Stud Positive Tstud = 25°C. I = see Col. 5, page 2. Measurement to be made between 5 and 10 secs after the application of current.			Z(BR)		Col. 6 page 2	$\Omega$

Table I  
GROUP A INSPECTION (Cont'd.)

Examination or Test	K1007/ NATO Ref.	Test Conditions		AQL %	Insp. Level	Sym- bol	Limits		Units
		Specific Conditions					Min.	Max.	
<u>SUBGROUP 2 (Cont'd.)</u> Small Signal Breakdown Impedance (2)	8A.4.1	Stud Negative $T_{stud} = 25^{\circ}\text{C}$ . I = see Col. 5, page 2. Measurement to be made between 5 and 10 secs after the application of current.				$Z_{(BR)}$	Col. 6 page 2		$\Omega$
<u>SUBGROUP 3</u> Small Signal Breakdown Impedance (3)	8A.4.1	Stud Positive $T_{stud} = 25^{\circ}\text{C}$ . I = 1 mA.		2.5	I	$Z_{(BR)}$	Col. 7 page 2		$\Omega$
Small Signal Breakdown Impedance (4)	8A.4.1	Stud Negative $T_{stud} = 25^{\circ}\text{C}$ . I = 1 mA.				$Z_{(BR)}$	Col. 7 page 2		$\Omega$
<u>SUBGROUP 4</u> Temperature Coefficient of Operating Voltage	8A.7.3	Stud Positive I = see Col. 5, page 2. $T_1 = 25^{\circ}\text{C} + 5^{\circ}\text{C}$ . $T_2 = 100^{\circ}\text{C} + 5^{\circ}\text{C}$ . Single shot pulse, 0.1 sec duration, max. tr and tf = 10 nS. Note:- Measured values of $T_1$ and $T_2$ to be used in calculating $S_z$ .				$S_z$	Col. 2 page 3 Col. 4 page 3		%/ $^{\circ}\text{C}$



GROUP A INSPECTION (Cont'd.)

Table I

Examination or Test	Test Conditions		AQL %	Insp. Sym- bol	Limits		Units
	K1007/ NATO Ref.	Specific Conditions			Min.	Max.	
SUBGROUP 4 (Cont'd.) Temperature Coefficient of Operating Voltage	8A.7.3	<p>Stud Negative I = see Col. 5, page 2. T<sub>1</sub> = 25°C ± 5°C. T<sub>2</sub> = 100°C ± 5°C. Single shot pulse, 0.1 sec duration, max. t<sub>r</sub> and t<sub>f</sub> = 10 nS.</p> <p>Note:- Measured values of T<sub>1</sub> and T<sub>2</sub> to be used in calculating S<sub>Z</sub>.</p>		S <sub>Z</sub>	Col. 2 page 3	Col. 4 page 3	

Table II

GROUP B INSPECTION

See page 4. Quality Assurance Provisions and Requirements

Examination or Test	K1007/ NATO Ref.	Test Conditions Specific Conditions	AQL Q	Insp. Sym- Level bel	Limits		Units
					Min.	Max.	
<u>SUBGROUP 1</u> Physical Dimensions	5.1	According to Drawing 10.3.3.2 and Fig. 2 page 14.	6.5	IC			
<u>SUBGROUP 2</u> Solderability	5.13		6.5	IC			
Temperature Cycling	5.5	-55°C to +150°C.					
Moisture Resistance	5.3						
<u>SUBGROUP 3</u> Vibration Fatigue	5.15	Non-operating					
<u>SUBGROUP 4</u> Omitted							
<u>SUBGROUP 5</u> Omitted							
<u>SUBGROUP 6</u> Omitted							

GROUP B INSPECTION (Cont'd.)

Examination or Test	K1007/ NATO Ref.	Test Conditions	AQL %	Insp. Level	Sym- bol	Limits		Units
						Min.	Max.	
<u>SUBGROUP 7</u> High Temperature Life (Non-operating)	6.2.1 6.6.1.2.2	T <sub>amb</sub> = 150°C t = 1000 hrs.	6.5	IC				
<u>SUBGROUP 8</u> Operating Life	6.3 6.5 6.6.1.1 6.6.1.2.2	T <sub>stud</sub> not greater than 140°C. Current to give dissipation not less than the value corresponding to the chosen T <sub>stud</sub> according to the derating curve Fig. 1 page 13. Current to pass through the device in each direction such that at the end of the test period the total times in each direction are equal.	4.0	IA				
<u>Post Test End Points for Subgroups 2, 3, 7 and 8</u> Breakdown Voltage (1)	8A.2.4	As in Group A Inspection, Subgroup 2.			V(BR)	Col. 3 page 2	Col. 4 page 2	V
Breakdown Voltage (2)	8A.2.4	As in Group A Inspection, Subgroup 2.			V(BR)	Col. 3 page 2	Col. 4 page 2	V

Table II  
GROUP B INSPECTION

Examination or Test	Test Conditions		AQL %	Insp. Level	Sym-bol	Limits		Units
	K1007/ NATO Ref.	Specific Conditions				Min.	Max.	
Post Test End Points for Subgroups 2, 3, 7 and 8 (Cont'd)								
Small Signal Breakdown Impedance (3)	8A.4.1	As in Group A Inspection, Subgroup 3.			Z(BR)		Col. 5 page 3	Ω
Small Signal Breakdown Impedance (4)	8A.4.1	As in Group A Inspection, Subgroup 3.			Z(BR)		Col. 5 page 3	Ω

GROUP C INSPECTION

See Page 4. Quality Assurance Provisions.

Examination or Test	K1007/ NATO Ref.	Test Conditions		AQL %	Insp. Level	Sym- bol	Limits		Units
		Specific Conditions					Min.	Max.	
<u>SUBGROUP 1</u> Omitted.									
<u>SUBGROUP 2</u> Shook	5.17	Non-operating. Five blows each orientation : Y1, Y2, X and Z.		6.5	IA				
<u>Post Test End Point for Subgroup 2</u> Breakdown Voltage (1)	8A.2.4	As in Group A Inspection, Subgroup 2.				V(BR)	Col. 3 page 2	Col. 4 page 2	V
Breakdown Voltage (2)	8A.2.4	As in Group A Inspection, Subgroup 2.				V(BR)	Col. 3 page 2	Col. 4 page 2	V
Small Signal Breakdown Impedance (3)	8A.4.1	As in Group A Inspection, Subgroup 3.				Z(BR)		Col. 7 page 2	Ω
Small Signal Breakdown Impedance (4)	8A.4.1	As in Group A Inspection, Subgroup 3.				Z(BR)		Col. 7 page 2	Ω

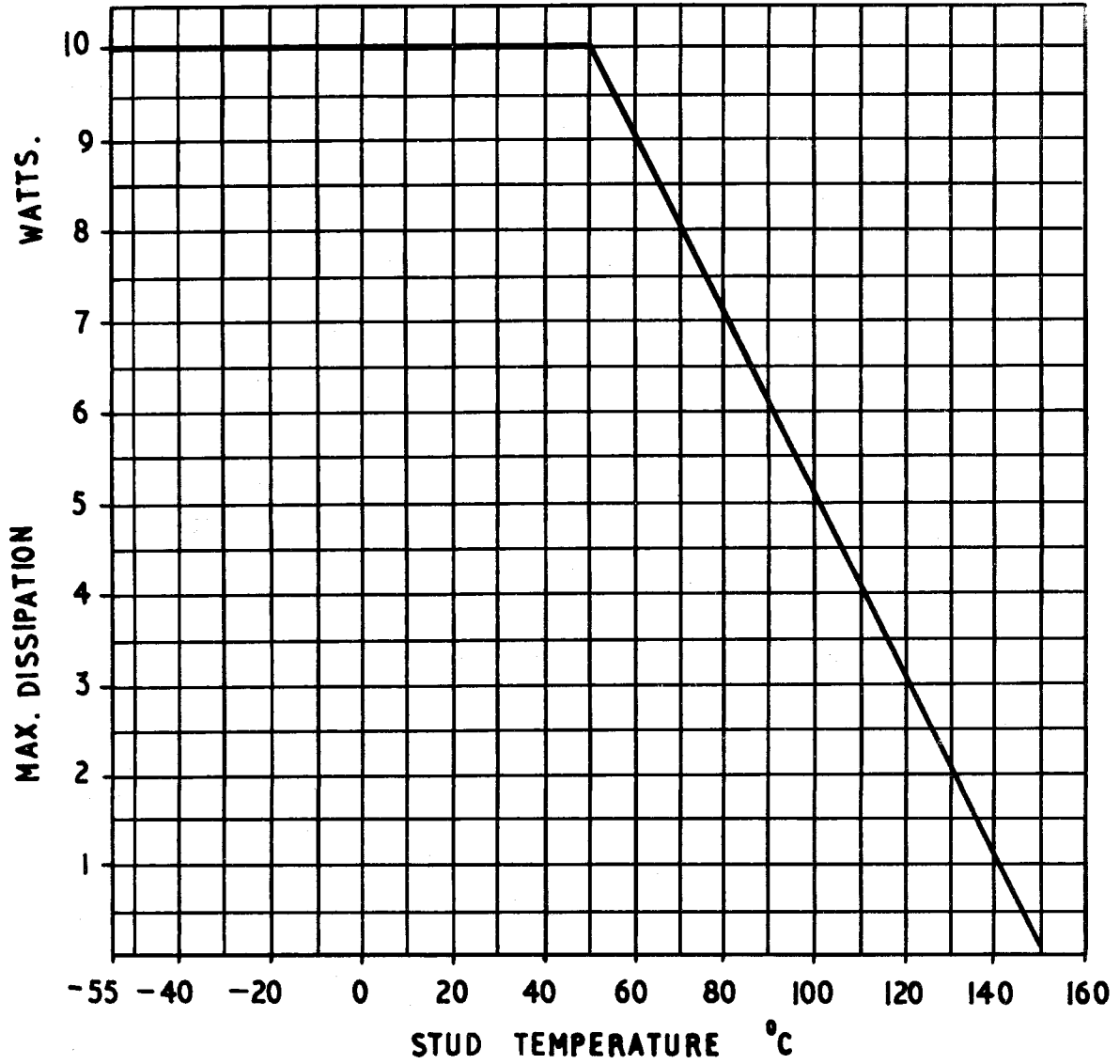
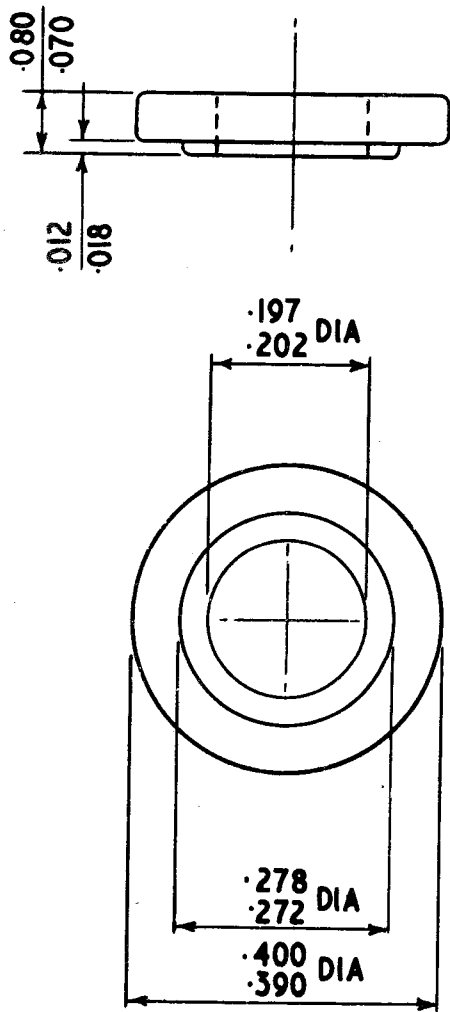
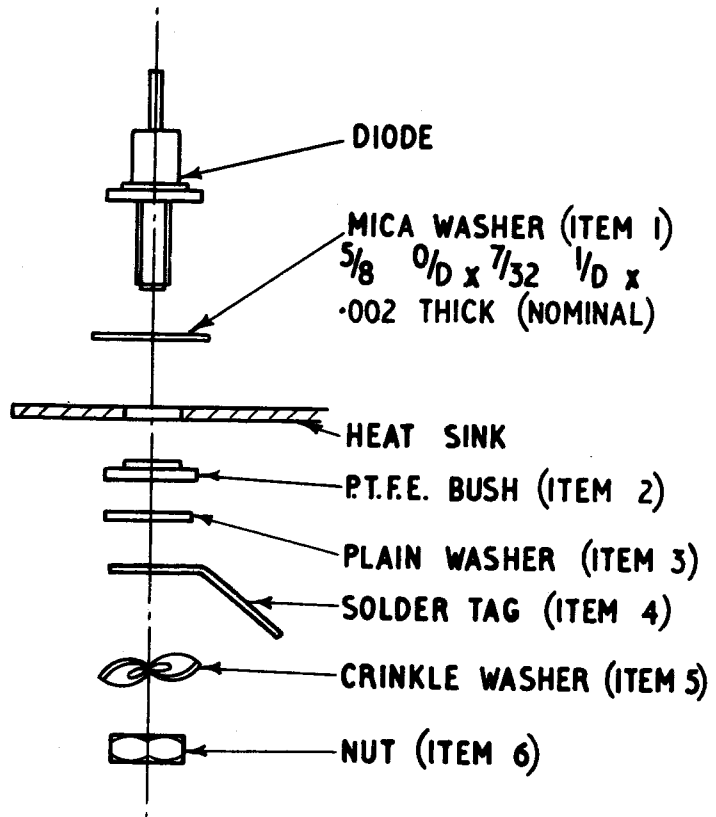

FIG. I.

POWER DERATING



**P.T.F.E. BUSH**  
(ITEM 2)  
SCALE:- 4/1



**TYPICAL ASSEMBLY**  
SCALE 1/1

ALL METAL PARTS TO  
BE TINNED

MOUNTING TORQUE, WITH DRY  
THREAD = 12 IN. IBS. MIN.  
15 IN. IBS. MAX.

**FIG. 2.**